

# How To Solder

## Items Needed:

- ✓ **Smaller Soldering Iron:** Available at any electronics supply store or order PMD Part#1207
- ✓ **Soldering Paste:** Available at any electronics supply store or order PMD Part#1208
- ✓ **Solder With Rosin Core (For Electronics):** Available at any electronics supply store
- ✓ **Shrink Tubing:** Available at any electronics supply store
- ✓ **Heat Gun:** Available at any electronics supply store or order PMD Part#1202

**NOTE:** Read all the instructions completely before starting. We suggest that you practice on scrap wire before working on your main project. Before soldering on wires on a electronic device, always disconnect the battery (power source) and make sure the area is well ventilated.

## Soldering Two Wires Together

Set up a safe way to rest the soldering iron, let it heat up.

**NOTE:** Electronic anti-static matte preferably.

Strip an 1/8" off the end of each wire that is to be spliced together.

Wipe the bare wire of both pieces with soldering paste using the small brush supplied with the tin of paste (fig 1).

Take the hot soldering iron and melt a small drop of solder on the tip of the iron from the solder roll. Touch the iron to the tip of the first wire [A] (fig 2).

**NOTE:** The solder will very quickly flow into the wire, remove iron .

Select the correct size shrink tubing, cut a small length and place it over the end of the other wire [B] and slide it back so it does not to get hot from soldering the wires together.

Using a "Helping Hand" to hold one of wires [A], then take the other wire [B] and butt or overlap it, end to end with the first wire [A].

**NOTE:** A "Helping Hand" is a bench tool that has clamps that is used to hold small items. Available at any electronics supply store or order PMD Part#1200 for the "Pro Builders Kit", which includes a "Helping Hands".

Take the hot soldering iron and put another drop of solder on it. Then put the soldering iron to the two wires being held together. You will have a strong solder joint (fig 3).

**NOTE:** The solder will very quickly flow into the wire, remove iron .

Slide the shrink tubing over the joint and apply heat with a heat gun to shrink the tubing snugly around the joint (fig 4).

**NOTE:** Don't over expose the wires to the heat source.



(fig 1)

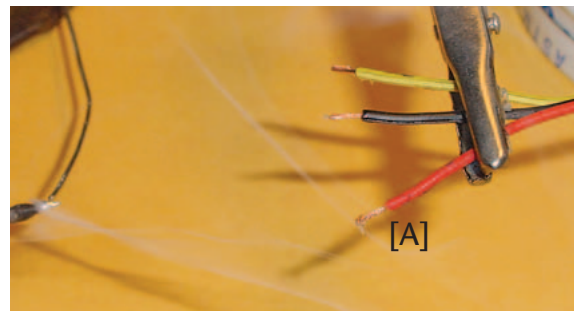

(fig 2)



(fig 3)

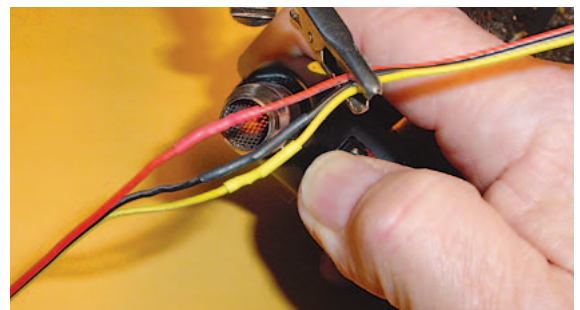

(fig 4)

# Soldering A Wire To A Printed Circuit Board.

Set up a safe way to rest the soldering iron, let it heat up.

**NOTE:** Electronic anti-static matte preferably.

Strip about 1/8" of wire, apply soldering paste to the bare wire and to the hole in the PC Board (fig 5), insert the wire into the desired hole (fig 6).

**NOTE:** All soldering is on the back of a PC Board.

Take the hot soldering iron and get a drop of solder on the tip, then touch the tip of the iron to the wire protruding through the hole in the PC Board. The drop of solder will transfer very quickly to the wire and PC Board flowing out to form a smooth solder joint. As soon as you see this happen remove the soldering iron (fig 7).

**NOTE:** Do not touch the PC Board with the soldering iron!

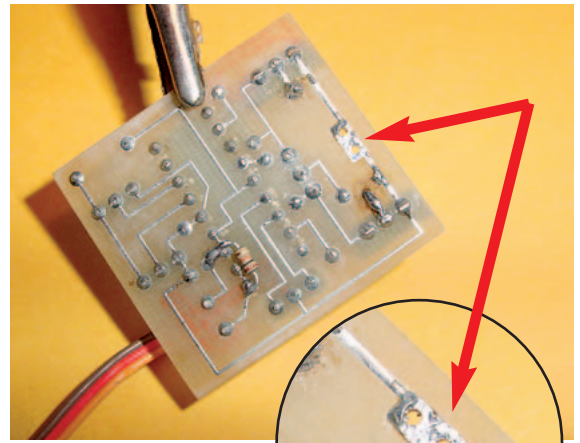

(fig 5)

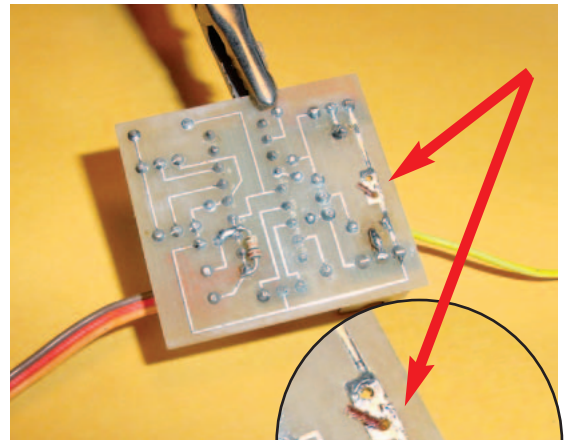

(fig 6)

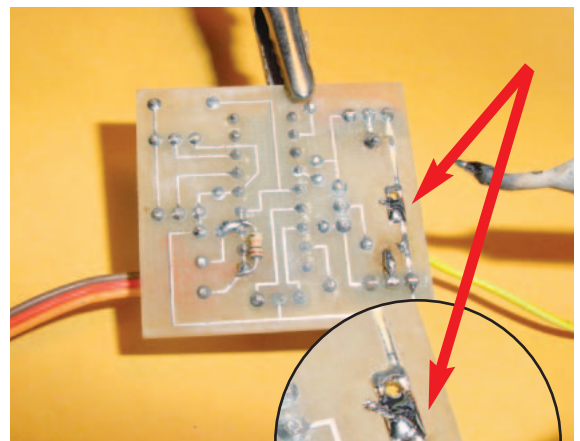

(fig 7)